

Rod ends with female thread: KBRM and KBLM



Standard design



Stainless steel sleeve
version (MH)

- Predecessor model of KCRM
 - Maintenance-free dry operation
 - High rigidity
 - Very high durability under alternating loads
 - Compensation of misalignment errors
 - Compensation of edge loads
 - Resistant to dirt, dust and lint
 - Resistant to corrosion and chemicals
 - Vibration-dampening
 - Suitable for rotating, oscillating and linear movements
 - Lightweight
 - Dimensional series K following DIN ISO 12240
 - Available with stainless steel sleeve for higher tightening torque
 - Adapter screw with circlip available
- ▶ Accessories, page 1015



Online service life calculation
▶ www.igus.eu/igubal-expert

Technical data

Part No.	Max. static tensile strain		Max. static axial load		Min. thread depth Threads [mm]	Max. tightening torque Female thread [Nm]	Max. tightening torque through ball		Weight [g]
	Short-term [N]	Long-term [N]	Short-term [N]	Long-term [N]			without stainless steel sleeve [Nm]	with stainless steel sleeve [Nm]	
KB□M-02	200	100	50	25	4	0.30	1	–	0.4
KB□M-03	800	400	100	50	5	0.50	2	4	2.7
KB□M-05-M4	1,000	500	250	125	7	0.75	5	12	3.5
KB□M-05	1,000	500	250	125	7	1.00	5	12	3.4
KB□M-06	1,400	700	400	200	8	1.50	10	15	4.7
KB□M-08	2,100	1,050	700	350	11	5.00	12	40	8.6
KB□M-10	3,100	1,550	800	400	13	15.00	20	50	14.6
KB□M-10-F	3,100	1,550	800	400	13	6.00	20	50	14.6
KB□M-12 ¹²⁹⁾	3,600	1,800	900	450	15	20.00	30	70	22.0
KB□M-12-F	3,600	1,800	900	450	15	15.00	30	70	22.0
KB□M-14	4,000	2,000	1,000	500	17	25.00	35	75	30.9
KB□M-14-F	4,000	2,000	1,000	500	17	25.00	35	75	30.9
KB□M-16	4,200	2,100	1,300	650	19	30.00	40	110	39.6
KB□M-16-F	4,200	2,100	1,300	650	19	27.50	40	110	39.6
KB□M-18	4,600	2,300	1,600	800	21	45.00	45	150	55.0
KB□M-20	5,400	2,700	2,100	1,050	22	60.00	55	200	73.5
KB□M-20-M20	5,400	2,700	2,100	1,050	22	60.00	55	200	73.5
KB□M-22	7,000	3,500	2,200	1,100	25	75.00	60	–	94.8
KB□M-25	8,500	4,250	2,300	1,150	28	120.00	60	–	119.8
KB□M-30	10,500	5,250	2,500	1,250	34	135.00	60	–	177.0
KB□M-30-M27x2	10,500	5,250	2,500	1,250	34	135.00	60	–	189.6

¹²⁹⁾ Integrated lock nut. Drawing as for KCRM, page 879

Rod ends with female thread: KBRM and KBLM



Order key

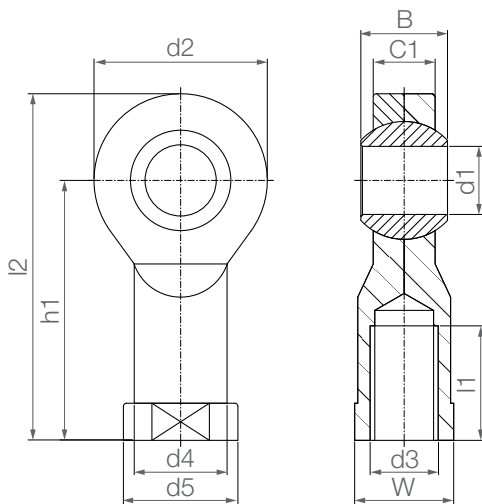

Type	Size	Options
K B □ M- 02 - MH		
K series	Housing (female thread)	Thread
	Thread	Metric
	Inner Ø [mm]	
		Thread
		L : Left-hand thread
		R : Right-hand thread
		Add-on:
		MH : With stainless steel sleeve
		F : Fine thread



Material:

Housing: **igumid® G** ► Page 1190

Spherical ball: **igidur® W300** ► Page 175



Imperial dimensions available

► Page 1154

Dimensions [mm]

Part No.	d1	d2	d3	d4	d5	C1	B		h1	l1	l2	W	Max. pivot angle
							without stainless steel sleeve	with stainless steel sleeve					
	E10							+0.2					
KB□M-02	2	9	M2	4.0	4.6	3.0	4	–	12.5	6	17	SW4	30°
KB□M-03	3	13	M3	6.5	8.0	4.5	6	6.2	18.5	8	25	SW6	30°
KB□M-05-M4	5	18	M4	9.0	12.0	6.0	8	8.2	27	10	36	SW9	30°
KB□M-05	5	18	M5	9.0	12.0	6.0	8	8.2	27	10	36	SW9	30°
KB□M-06	6	20	M6	10.0	13.0	7.0	9	9.2	30	12	40	SW11	29°
KB□M-08	8	24	M8	13.0	16.0	9.0	12	12.2	36	16	48	SW14	25°
KB□M-10	10	30	M10	15.0	19.0	10.5	14	14.2	43	20	58	SW17	25°
KB□M-10-F	10	30	M10 x 1.25	15.0	19.0	10.5	14	14.2	43	20	58	SW17	25°
KB□M-12	12	34	M12	–	–	12.0	16	16.2	50	25	67	SW17	25°
KB□M-12-F	12	34	M12 x 1.25	18.0	22.0	12.0	16	16.2	50	22	67	SW19	25°
KB□M-14	14	38	M14	20.0	25.0	13.5	19	19.2	57	25	76	SW22	25°
KB□M-14-F	14	38	M14 x 1.5	20.0	25.0	13.5	19	19.2	57	25	76	SW22	25°
KB□M-16	16	42	M16	22.0	27.0	15.0	21	21.2	64	28	85	SW22	23°
KB□M-16-F	16	42	M16 x 1.5	22.0	27.0	15.0	21	21.2	64	28	85	SW22	23°
KB□M-18	18	46	M18 x 1.5	25.0	31.0	16.5	23	23.2	71	32	94	SW27	23°
KB□M-20	20	50	M20 x 1.5	28.0	34.0	18.0	25	25.2	77	33	102	SW30	23°
KB□M-20-M20	20	50	M20 x 2.5	28.0	34.0	18.0	25	25.2	77	33	102	SW30	23°
KB□M-22	22	56	M22 x 1.5	30.0	37.0	20.0	28	–	84	37	112	SW32	22°
KB□M-25	25	60	M24 x 2.0	32.0	41.0	22.0	31	–	94	42	124	SW36	22°
KB□M-30	30	70	M30 x 2.0	37.0	50.0	25.0	37	–	110	50	145	SW41	22°
KB□M-30-M27x2	30	70	M27 x 2.0	37.0	50.0	25.0	37	–	110	50	145	SW41	22°

Rod ends can be ordered in metric dimensions with stainless steel sleeve with the addition of MH after the part numbers listed here. Example: KBRM-10-MH (Inner Ø: 10mm).